

GRA112V

3U VPX High Performance Dual Channel Graphics Boards with Legacy Video Output

The GRA112V is the third generation of 3U VPX graphics boards, bringing the NVIDIA® Kepler graphics processing unit to the rugged military and aerospace market for both video and graphics generation and general purpose computing (GPGPU).

For both runtime performance and ease of programming, NVIDIA's EXK107 GPU enables significant gains in SIGINT, radar and video or image processing applications. With 384 processing cores, single- and double-precision floating point units, improved shared memory architecture and cache hierarchy, together with faster atomic operations, the GRA112V's EXK107 GPU is capable of CUDA Compute Capability v3.0.

The 3U VPX form factor of the Abaco Systems GRA112V allows maximum bandwidth connectivity between NVIDIA's EXK107 GPU and the system backplane, routing the full 16 lanes of Gen 3-capable PCI Express® to the backplane for connection to a CPU, such as an Abaco SBC based on the latest version of Intel Core i7 processor. This high-bandwidth interconnect helps reduce latency, particularly in applications which transfer large volumes of data to the GPU for processing.

In order to support legacy platforms, the GRA112V implements a scan-converter on one of the RGB analog outputs, allowing the product to drive an interlaced video output. The sync signals can be separate, composite

or sync on green, and the video signal can be single-ended or differential.

Designed to be pin-compatible with Abaco's GRA111, the GRA112V offers two independent graphics channels in both analog VESA and digital DVI formats.

This high-performance graphics card is available in four of Abaco's standard rugged build levels, from benign lab environments to wide-temperature rugged conduction-cooled, and in a two-level maintenance (2LM) VITA 48-REDI variant with rear covers.

In critical applications where it is desirable to have a fast shutdown of computing equipment, an option exists for a fast power-supply discharge.

The GRA112V is a form, fit and function replacement for the GRA111, and may be deployed in the MAGIC1 Rugged Display Computer to provide a fast-to-market solution for high-performance graphics and GPGPU signal processing applications.



The GRA112V is optionally available as an LRM (Line Replaceable Module) in accordance with the VPX-REDI (VITA 48) standard.

FEATURES:

- NVIDIA® EXK107 GPU
 - NVIDIA Kepler architecture
 - 384 processor cores
 - 128-bit memory bus
 - 2 Gbytes GDDR5 SDRAM as used on NVIDIA GT 650M
- PCI Express
 - 16-lane PCIe Gen 3 capable (x16/x8/x4)
- Support
 - NVIDIA CUDA™ (compute capability 3.0)
 - OpenCL™
 - OpenGL
 - GPUBoost
 - NVIDIA H.264 video encoding (NVENC)
 - NVIDIA PureVideo® Technology (PUHD)
 - NVIDIA PhysX™
 - Microsoft® DirectX (Compute)
- Dual channel output
 - 2x digital DVI outputs
 - Up to WUXGA (1920x1200) @ 60 Hz
 - 2x analog outputs
 - Up to UXGA (1600x1200) @ 60 Hz
 - Legacy interlaced video support for STANAG3350, RS-170, and custom timings
- Air- and conduction-cooled variants
- 3U VPX form factor
- Available as 2LM VPX-REDI

GRA112V 3U VPX High Performance Graphics Board

Specifications

GPU

- NVIDIA EXK107

Video memory

- 2 GB GDDR5 SDRAM
- 128-bit wide memory interface

Number of channels

- Dual independent channels

RGB output

- VESA resolutions up to UXGA 1600x1200@60Hz on channel1
- Legacy video output; interlaced, sync-on-green or composite sync, single-ended or differential signaling, custom timings on channel 2

Digital output

- DVI 1.0 resolutions up to UXGA 1920x1200 @ 60 Hz on both channels

Form factor

- 3U OpenVPX

Fabric Interface

- Interconnection between GPU and CPU
- 16-lane PCI Express interface, Gen 3 capable

Environment

- Level 1: 0°C to +55°C air-cooled
- Level 2: -20°C to +65°C air-cooled
- Level 4: -40°C to +75°C conduction-cooled
- Level 9: -40°C to +85°C conduction-cooled

Drivers

- OpenGL 4.1 and DirectX 11 drivers for Microsoft Windows® and Linux® running on Intel host card

Power Requirements

- +5V / 3V3_Aux required

Block diagram

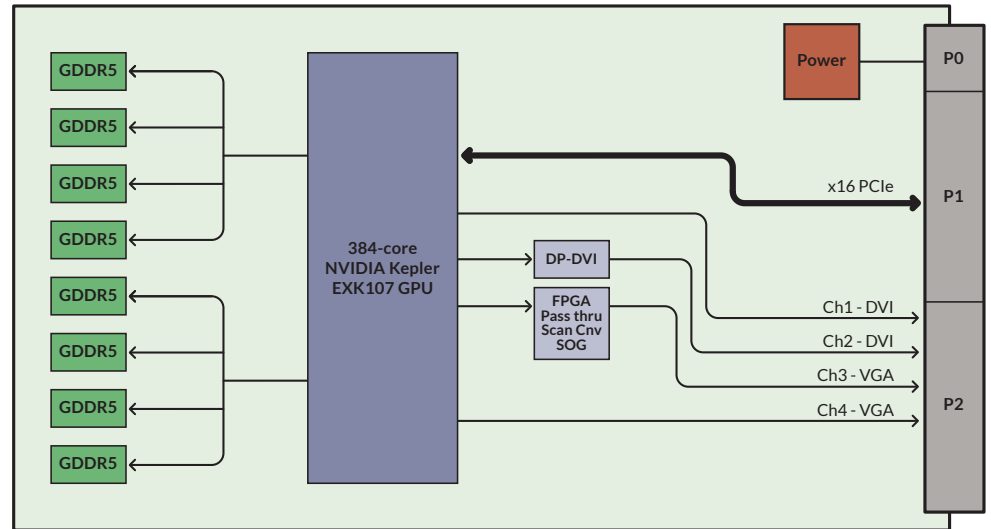

Ordering information

GRA112V	A	B	C	D	E	F	G	
	1							Level 1: 0°C to +55°C air-cooled
	2							Level 2: -20°C to +65°C air-cooled
	4							Level 4: -40°C to +75°C conduction-cooled
	9							Level 9: -40°C to +85°C conduction-cooled
		0						Reserved
			0					Single ended signalling
			1					Differential VGA signalling
				0				Sync on Green disabled
				1				Sync on Green enabled
					0			1V signalling + 0.293V sync
					1			1V signalling + 0.4V syncs
					2			0.7V signalling + 0.293V syncs
						0		Max performance BIOS
							1	0.8" pitch VITA 46
							3	1" pitch VITA 46
							6	1" pitch VITA 48
							B	0.85" pitch VITA 46 (2LM)

WE INNOVATE. WE DELIVER. YOU SUCCEED.

Americas: 866-OK-ABACO or +1-866-652-2226 Asia & Oceania: +81-3-5544-3973

Europe, Africa, & Middle East: +44 (0) 1327-359444

Locate an Abaco Systems Sales Representative visit: abaco.com/products/sales

abaco.com @AbacoSys

©2016 Abaco Systems. All Rights Reserved. All other brands, names or trademarks are property of their respective owners. Specifications are subject to change without notice.

