

PPC10A

6U VME QorIQ P4080-based Single Board Computer

The PPC10A is the latest Freescale QorIQ-based product to join Abaco Intelligent Platform's PowerXtreme family of rugged 6U VME Single Board Computers.

Based on the P4080, the PPC10A offers a huge leap in processing performance, providing up to eight processing cores within the power envelope of previous dual core boards. Combined with an extensive and flexible range of I/O options, the PPC10A is ideal for a wide range of high performance Mil/Aero applications.

Features of the QorIQ P4080 processor

- System on Chip (SoC) processor with eight high-performance e500mc cores built on Power Architecture Technology
- 45-nanometer technology delivers unprecedented performance per watt enabling power-efficient designs
- Quad and Octal-core options

The PPC10A supports a diverse I/O set that includes Gigabit Ethernet, fast serial COM ports, USB 2.0, SATA and GPIO.

Further incremental system resource expansion is provided by two mezzanine sites, both of which are XMC/PMC capable, and

offer the option of having XMC I/O and/or PMC I/O routed to the VME backplane connectors.

High speed XMC I/O is supported from Site 1 via the option of a high speed P0 connector.

In addition an AFIX site is available for yet more plug-on system expansion. The AFIX site not only allows access to the current range of standard AFIX modules (graphics, SCSI, 1553, digital I/O, Flash memory) but also offers the opportunity to add customer-specific features at minimum cost and in the shortest timescales.

Designed specifically for harsh environments, the PPC10A is ideal for Mil / Aero applications where high reliability and survivability are a must. Available in five air- and conduction-cooled ruggedization levels, the PPC10A offers a straight-forward upgrade path for both new customers and existing PowerXtreme users looking to modernize existing systems

The PPC10A is fully supported by comprehensive Deployed Test Software (BIT and BCS) with OS support planned for VxWorks®, Wind River Hypervisor, Linux®, and Integrity.

FEATURES:

- 6U VME Single Board Computer
- P4080 processor
- - Eight e500mc cores @ up to 1.5 GHz
- Dual-channel DDR3 (up to 8 GB)
- 512 MB NOR Flash
- 4 GB NAND Flash Solid-State Drive
- 512 kB non-volatile MRAM
- Host/Slave, VME64 Compliant + 2eSST support
- 2x Independent PMC/XMC Sites
- AFIX site (SCSI/VGA/1553/Flash drive)
- 2x 10/100/1000BaseT Ethernet + 2x optional 10/100/1000BaseT Ethernet
- 2x or 4x RS-232 Debug
- 4x RS-232/422/485 sync/async
- 2x Serial ATA (3 Gb/s)
- 2x USB 2.0 + 3x Optional USB 2.0
- Up to 31x Single-Ended GPIO (5V tolerant)
- Front I/O (air-cooled variants only)
- BMM Baseboard Management Controller

PPC10A 6U VME QorIQ P4080-based Single Board Computer

Specifications

Integrated Host Processor

- Freescale QorIQ P4080 @ up to 1.5 GHz
- Eight e500 cores with private L1 and L2 caches
- Double-precision floating-point support
- 2 MB shared Level 3 cache
- CoreNet internal fabric @ up to 800 MHz

DDR3 SDRAM

- Up to 8 GB DDR3 SDRAM with ECC (4 GB per bank)

Flash Memory

- 512 MB NOR Flash memory
- Protected BANC Boot Area
- 4 GB NAND Flash SATA Solid State Drive

Backplane

- Fully VME64 Host/slave capable with 2eSST support

Mezzanine Sites

- Two XMC/PMC sites with x8 PCI Express and/or 64-bit PCI-X at up to 133 MHz
- AFIX Site supporting Abaco daughter cards including dual-channel 1553, SCSI, Graphics and Flash Drive

Gigabit Ethernet

- 2x 10/100/1000BaseT Ethernet
- 2x 10/100/1000BaseT Ethernet ports as a build option over 8/16x GPIO

Rear I/O

- 2x/4x RS-232 UART ports
- 4x RS-232/422/485 async/sync ports
- 2x USB 2.0 + 3x optional
- 2x Serial ATA (3 Gb/s) to P0
- Up to 31, 5V-tolerant GPIO each capable of generating an interrupt

Front Panel I/O (Air-cooled boards only)

- Two connectors, each with serial, Ethernet and USB interfaces

NVRAM / Real-Time Clock / Watchdog / ETI

- 512 kB non-volatile MRAM
- Real-time clock with 1 second resolution
- 2x Watchdog timers (programmable 32-bit timer)
- Elapsed Time Indicator (records power cycles and on-time)

Temperature Sensors

- On-board ambient temperature

Power Requirements

- +5V main input power
- +5V Stand-by optional
- +/-12V only if required by mezzanine module

Block diagram

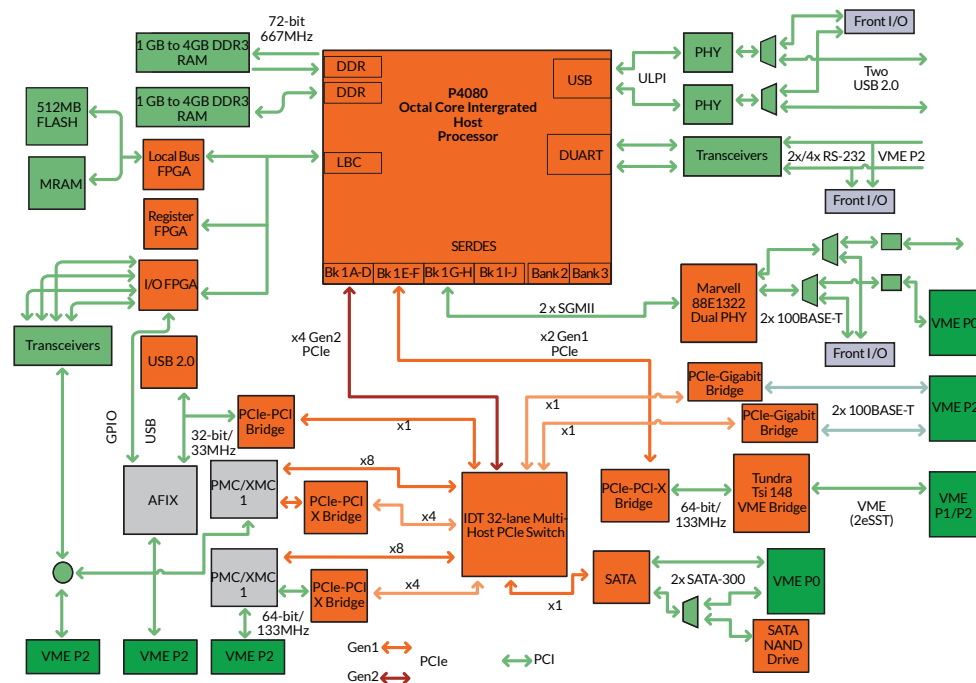

Ordering information

	Level 1	Level 2	Level 3	Level 4	Level 5
Cooling Method	Convection	Convection	Convection	Conduction	Conduction
Conformal Coating	Optional	Standard	Standard	Standard	Standard
High/Low Temp	0 to +55°C	-20 to +65°C	-40 to +75°C	-40 to +75°C	-40 to +85°C
Operational	(300 ft/m)	(300 ft/m)	(600 ft/m)	At cold wall	At cold wall
Random Vibration	0.002g2/Hz*	0.002g2/Hz*	0.04g2/Hz**	0.1g2/Hz**	0.1g2/Hz**
Shock	20g***	20g***	20g***	40g***	40g***

With a flat response to 1000 Hz, 6 dB/Oct roll-off from 1000 to 2000 Hz ** From 10 to 1000 Hz *Peak sawtooth 11 ms duration

WE INNOVATE. WE DELIVER. YOU SUCCEED.

Americas: 866-OK-ABACO or +1-866-652-2226 Asia & Oceania: +81-3-5544-3973

Europe, Africa, & Middle East: +44 (0) 1327-359444

Locate an Abaco Systems Sales Representative visit: abaco.com/products/sales

abaco.com @AbacoSys

©2016 Abaco Systems. All Rights Reserved. All other brands, names or trademarks are property of their respective owners. Specifications are subject to change without notice.

