

# SBC314

## 3U VPX QorIQ AMP T1042 / T2081-based Single Board Computer

The SBC314 is the first Freescale™ QorIQ™ AMP (advanced multiprocessing series) based product to join Abaco's VPXtreme3 family of rugged 3U VPX single board computers.

The SBC314 offers a high performance option based on the T2081 processor and a low power option based on the T1042 processor, allowing the user to select a solution tailored to their application.

- The T2081 brings the benefits of AltiVec co-processing to a 4-core platform, each of which is dual threaded, offering 8 virtual cores, consuming up to 25W.
- The T1042 is optimized for lower power consumption applications, offering 4 single threaded cores consuming less than 7.5W.

Combined with an extensive and flexible range of I/O options, the SBC314 is ideal for a wide range of high performance mil/aero applications.

Fully compatible with OpenVPX (VITA 65), the SBC314 offers multiple connectivity options via its highly configurable PCI Express™ fabric ports enabling a range of scalable solutions from single host and peripherals to larger multiprocessor systems.

In addition the SBC314 supports a diverse I/O set that includes Gigabit Ethernet, COM ports, USB 2.0, SATA and GPIO.

Further incremental system resource expansion is provided via an XMC/PMC-capable mezzanine site which offers the option of having either XMC I/O or PMC I/O routed to the VPX backplane connectors.

Designed specifically for harsh environments, the SBC314 is ideal for embedded and mil/aero applications where high reliability and survivability are a must. Available in five air- and conduction-cooled ruggedization levels, the SBC314 also offers VITA 48 formats for 2-level maintenance (2LM) requirements.

The SBC314 is fully supported by comprehensive Deployed Test Software (BIT and BCS) with operating system support planned for VxWorks® 6.x, 7, VxWorks653®; Open Source Linux®; Wind River Linux® and INTEGRITY™.

In addition, the SBC314 is also supported by Abaco Systems innovative P2P software, which supports the implementation of PCI Express peer-to-peer connectivity.

### FEATURES:

- 3U OpenVPX single board computer
- Power Architecture™ AMP (advanced multiprocessing) CPU's
  - T1042 (four e5500 cores)
  - T2081 (eight e6500 virtual cores)
- DDR3L (up to 8 GB)
- Up to 256 MB NOR Flash
- Up to 16 GB SLC NAND Flash
- 512 kB Autostore NVRAM
- PCIe Gen2 data plane ports from VPX P1 (options for 2 x4, 1 x4 + 4 x1, 8 x1)
- 1x PMC/XMC Site
- Up to 3x Gigabit Ethernet ports
- 2x RS-232/422 COM ports (or 4x RS-232)
- Up to 2x SATA ports
- 2x USB 2.0
- Up to 8x single-ended GPIO (5V tolerant)
- BMM (Board Management Microcontroller)
- VITA65 OpenVPX Compatible
  - MOD3-PAY-2F2T-16.2.5-3
  - MOD3-PAY-2F2U-16.2.3-3

# SBC314 3U VPX QorIQ AMP T1042 / T2081-based Single Board Computer

## Specifications

### Processor Node

- Support for T2081 or T1042 Freescale QorIQ AMP CPU's
- T2081 up to 1.8 GHz
  - Eight e6500 virtual cores (4 cores, dual threaded and with AltiVec co-processing)
  - Double-precision floating-point support
  - 2 MB banked L2 cache, 512MB platform cache

### DDR3L SDRAM

- Up to 8 GB DDR3L SDRAM with ECC (Single Bank)

### Flash Memory

- Up to 256 MB NOR Flash memory
- Protected BANC Boot Area
- Up to 16 GB NAND Flash memory

### Fabric

- Two x4 PCIe Gen2 links from VPX P1 (one can be configured as a non-transparent port)
- Each link can be optionally configured as four x1 PCIe

### Gigabit Ethernet

- 2x 1000BASE-T or 1x 1000BASE-T + 2x 1000BASE-X as standard (P1 rear I/O)
- Additional 1000BASE-T port available (P1 rear I/O) as an option instead of 1x SATA port and 4 GPIO ports

### Serial I/O

- 2x RS-232/422 UART ports (P1/P2 rear I/O)

### USB

- 2x USB 2.0 (P1 rear I/O)

### SATA

- 2x SATA (300 MB/s) (P1 rear I/O). Lose one port if additional Ethernet port is required (as above). Lose one port if on-board NAND selected

### General Purpose I/O

- Up to 8 GPIO (P1 rear I/O), 5V tolerant GPIO each capable of generating an interrupt.

### PMC / XMC Extension Slot

- x4 PCIe XMC site (P2 rear I/O)
- PCI-X PMC site (P2 rear I/O)

### NVRAM / Real-Time Clock / Watchdog / ETI

- 512 kB Autostore NVRAM
- Real-time clock with 1 second resolution
- 2x Avionics-style Watchdog timers (programmable 32-bit timer)
- Elapsed Time Indicator (record power cycles and on-time)

### Temperature Sensor

- Onboard ambient temperature

### Power Requirements

- +5V required
- +/-12V only if required by mounted PMC module

## Block diagram

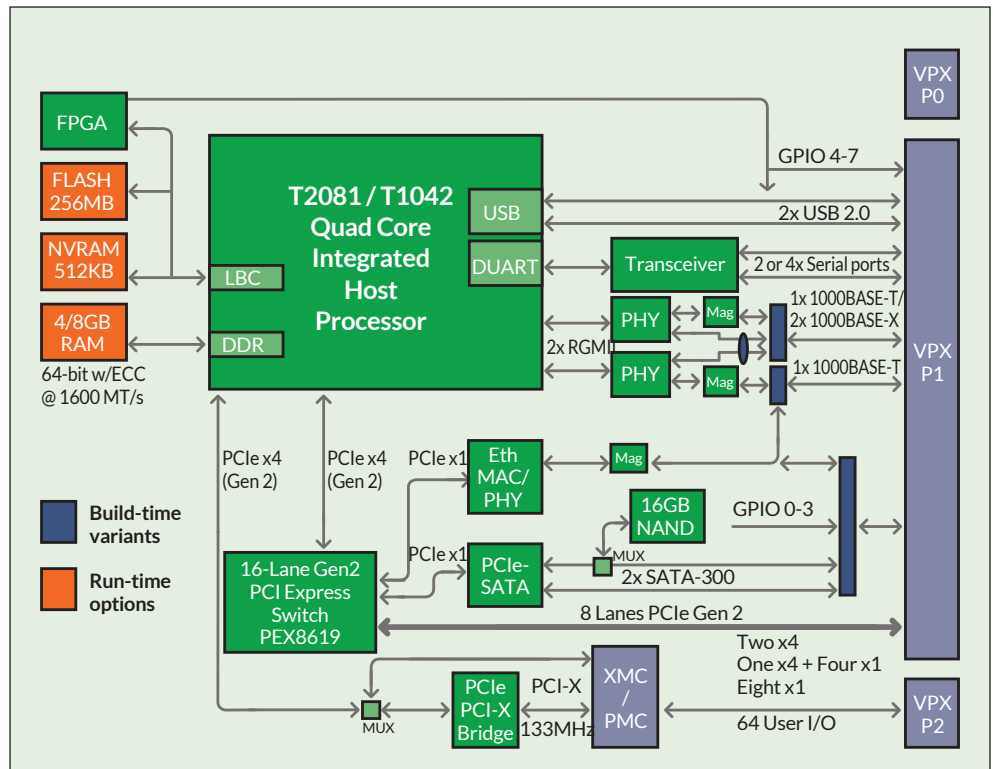

## Environmental

	Level 1	Level 2	Level 3	Level 4	Level 5
Cooling Method	Convection	Convection	Convection	Conduction	Conduction
Conformal Coating	Optional	Standard	Standard	Standard	Standard
High/Low Temp	0 to +55°C	-20 to +65°C	-40 to +75°C	-40 to +75°C	-40 to +85°C
Operational	(300 ft/m)	(300 ft/m)	(600 ft/m)	At cold wall	At cold wall
Random Vibration	0.002g2/Hz*	0.002g2/Hz*	0.04g2/Hz**	0.1g2/Hz**	0.1g2/Hz**
Shock	20g***	20g***	20g***	40g***	40g***

\* With a flat response to 1000 Hz, 6 dB/Oct roll-off from 1000 to 2000 Hz \*\* From 10 to 1000 Hz \*\*\* Peak sawtooth 11 ms duration

## WE INNOVATE. WE DELIVER. YOU SUCCEED.

Americas: 866-OK-ABACO or +1-866-652-2226 Asia & Oceania: +81-3-5544-3973

Europe, Africa, & Middle East: +44 (0) 1327-359444

Locate an Abaco Systems Sales Representative visit: [abaco.com/products/sales](http://abaco.com/products/sales)

[abaco.com](http://abaco.com) @AbacoSys

©2016 Abaco Systems. All Rights Reserved. All other brands, names or trademarks are property of their respective owners. Specifications are subject to change without notice.

